

# TECHNICAL SPECIFICATIONS

## UHMWPE Lined Ball Valves

Series 300 UL-T-H

Sizes 1" - 8"



### 1. SCOPE

Composite Ball Valve with Ultra High Molecular Weight Polyethylene liners and ball for erosive and corrosive service.

### 2. SERVICE RATING

Maximum continuous service temperature: 180°F

See P/T graph on P.2 for ratings

### 3. MATERIALS OF CONSTRUCTION

- (1) **Body:** Graphite Filled Vinyl Ester Composite.
- (2) **Packing Bolts and Gland:** Hastelloy-C with Hastelloy-C gland.
- (3) **Stem:** Hastelloy-C encapsulated with graphite-filled vinyl ester. Solid Hastelloy-C is optional.
- (4) **Stem Packing:** PTFE V-Rings.
- (5) **Seat Retainers:** Graphite Filled Vinyl Ester.
- (6) **Thrust Washer:** Glass and graphite filled PTFE.
- (7) **Ball:** Magnesia-partially stabilized (Mg-PSZ) Zirconia Ceramic.
- (8) **Liners:** Ultra-High Molecular Weight Polyethylene (UHMWPE)
- (9) **Liner Seals:** PTFE coated Viton o-rings.
- (10) **Operators:** Composite lever (1"-4"). Stainless Steel handle adapter (5"-8"). All handles have locking provision. Gear is recommended on 6" & 8".

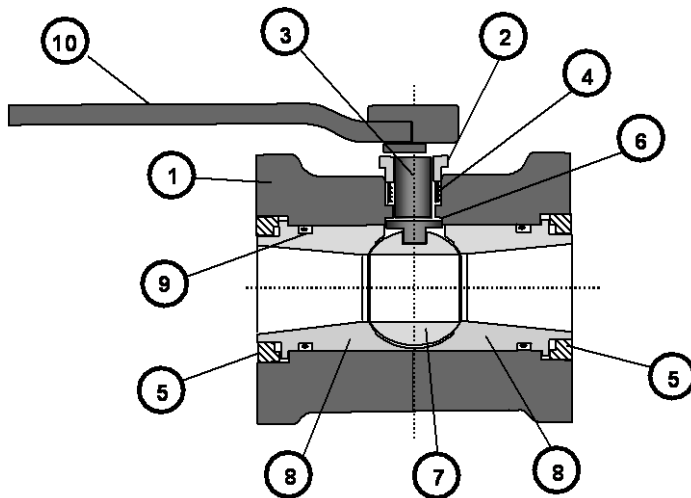

### 4. DESIGN

- Valves shall be flanged and conform to the face-to-face dimensions of ANSI/ASME B16.10.
- Valve shall have integral 4-bolt mounting pads and threaded holes for actuator mounting.
- Stems shall be blowout proof.
- Valves shall have a regular port with ball dimensions as shown on Page 2.
- Flanges shall be flat-faced with serrated finish to allow installation in metallic, lined metal, FRP, and thermoplastic piping systems.
- Flange bolt sizes and spacing shall conform to ANSI B16.5 Class 150. DIN, JIS and BS shall be available.
- Disassembly, maintenance and replacement of any parts shall not require machining or bonding.
- Ball and stem strength shall be sufficient to operate with abrasive particles filling the cavity.

### 5. QUALITY ASSURANCE

- The Manufacturer's facility shall be certified to ISO 9001 or equivalent. The Manufacturer shall be certified to the European Pressure Equipment Directive (PED) and the "CE" mark shall be affixed to each valve label.
- Each valve shall be hydrostatically shell tested at 1.5 x rated CWP for 3 minutes.
- Each valve shall be seat tested with air at 80 psig, or water at 1.1 x rated CWP, in both flow directions. Leakage past the seat shall meet the requirements of ANSI/FCI B16.104 Class IV (.01% of rated Cv).

### 6. PACKING AND SHIPPING

Valves shall be shipped in a closed position with both ends capped to exclude dirt and properly boxed to avoid damage. Each valve shall be marked with the manufacturer, valve size, model, serial number, and valve component designations.

### 7. AVAILABILITY

Valves meeting this specification are available from:

Nil-Cor®, LLC  
4855 Broadmoor Ave.  
Kentwood, MI 49512  
P: 616-554-3100  
F: 616-554-5623  
[www.nilcor.com](http://www.nilcor.com)

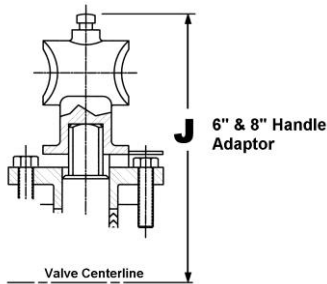
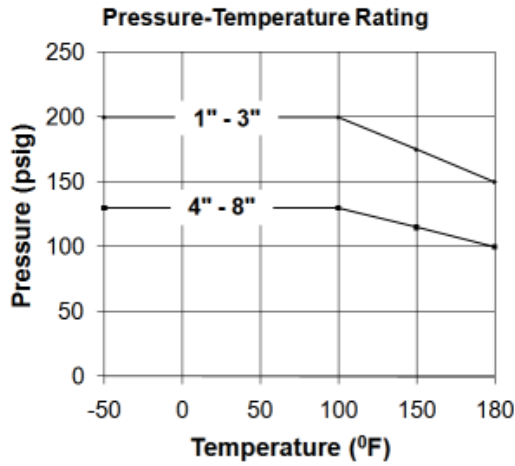

Note: Use 18" length of 1" sch. 40 pipe w/handle adaptor

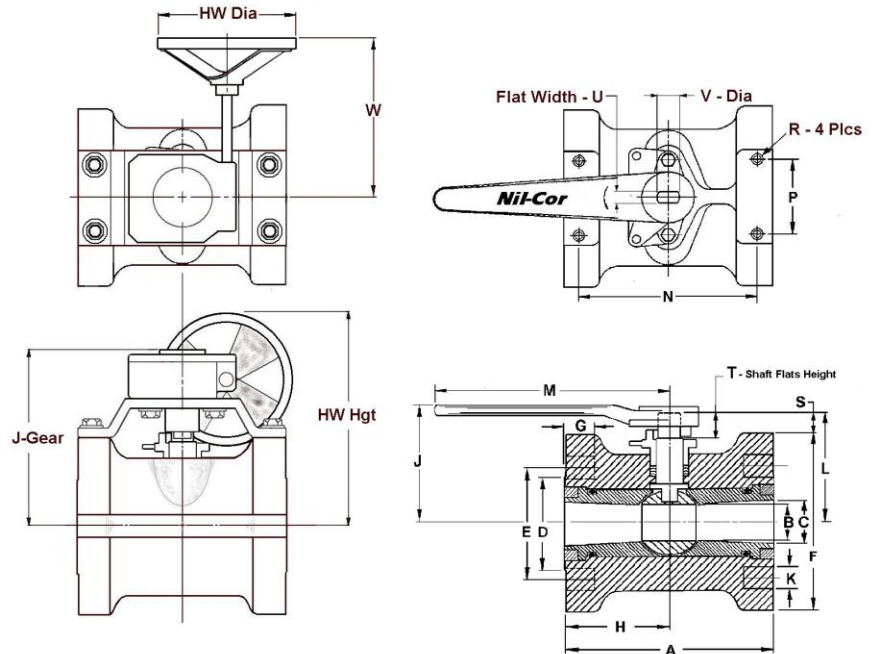

SIZE	A	B	C	D	E	F	G	H	J-Lever	J-Gear	HW Dia	HW Hgt	K	K (QTY)	L	M	W
1"	5.00	.88	1.00	2.25	3.13	4.25	.88	2.50	3.08	5.60	8	8.00	.62	4	2.77	6.25	6.32
1-1/2"	6.50	1.25	1.50	3.00	3.88	5.00	1.00	3.25	3.73	6.53	8	8.92	.62	4	3.55	6.25	6.32
2"	7.00	1.50	2.00	3.66	4.75	6.00	1.00	3.50	4.18	6.71	8	9.11	.75	4	3.96	9.00	6.32
2-1/2"	7.50	1.88	2.50	4.25	5.50	7.00	1.19	3.75	5.44	8.52	8	10.92	.75	4	5.17	9.00	6.32
3"	8.00	2.31	3.00	5.00	6.00	7.50	1.36	4.00	5.58	8.52	8	10.92	.75	4	5.42	9.00	6.32
4"	9.00	3.00	4.00	6.19	7.50	9.00	1.50	4.50	7.05	9.56	8	11.96	.75	8	6.50	11.44	6.32
5"	10	3.75	5.00	7.50	8.50	10.00	1.50	5.00	7.75	11.08	12	14.46	.88	8	7.21	Note 4	7.39
6"	10.50	4.50	6.00	8.50	9.50	11.00	1.63	5.25	10.51	11.58	12	14.96	.88	8	7.91	Note 4	7.39
8"	11.50	6.00	8.00	11.25	11.75	13.50	1.75	5.75	11.77	13.00	12	17.11	.88	8	9.21	Note 4	8.77

Valve Size	Actuation Mounting Dimensions					Actuation Torque (in-lbs.)			Weight (Lbs.)				
	N	P	R x (deep <sup>1</sup> )	S	T	+0.000-.010 U	+0.000-.010 V	Valve Running Torque <sup>(2)</sup>	Breakaway Torque <sup>(3)</sup> 0-100 psi	Breakaway Torque <sup>(3)</sup> >100 psi	Flow Coeff. Max Cv	w/o Gear (lbs.)	With Gear (lbs.)
1"	4.18	1.75	5/16 - 18 x 1/2	0.64	0.50	0.375	0.500	90	140	160	75	3	9
1-1/2"	5.62	1.75	5/16 - 18 x 1/2	1.05	0.70	0.375	0.500	125	190	230	115	6	12
2"	6.18	2.25	5/16 - 18 x 5/8	0.96	0.75	0.375	0.625	150	230	270	135	8	15
2-1/2"	6.62	2.63	3/8 - 16 x 3/4	1.67	0.75	0.500	0.880	260	400	475	250	13	20
3"	7.12	3.50	3/8 - 16 x 3/4	1.67	0.75	0.500	0.875	370	570	680	350	14	21
4"	8.00	4.00	7/16 - 14 x 7/8	2.00	1.13	0.750	1.000	680	1040	1250	540	23	30
5"	9.00	4.75	7/16 - 14 x 7/8	2.21	1.13	0.750	1.000	1000	1570	1825	1000	33	46
6"	9.00	5.25	7/16 - 14 x 1-1/8	2.41	1.13	0.750	1.000	1400	2100	2400	1240	40	53
8"	9.75	6.00	1/2 - 13 x 1-1/4	2.46	1.13	1.094	1.250	2800	4200	4800	2200	65	90

1. Minimum thread engagement required to develop design joint strength on the actuator mounting pad (composite valve body).
2. Normally expected operating torque for slurry applications. Verify with Nil-Cor on each application.
3. Standard Port configuration. Consult factory for control ball C<sub>v</sub> selections.