

TECHNICAL SPECIFICATIONS

DIN PN10

Wafer Butterfly Valves: 3"– 12"

Series 310 Fiberglass Reinforced Vinyl Ester



1. SCOPE

Flangeless Wafer Butterfly Valves for corrosive chemical service used in construction of pressurized piping systems.

2. SERVICE RATING

Continuous temperature service from -50 to 250° F. Short-term exposures to 300° F are acceptable.

Pressure ratings are as shown on P/T chart on reverse side of this page.

3. MATERIALS OF CONSTRUCTION

- (1) **Body:** Glass fiber reinforced vinyl ester resin
- (2) **Disc:** 3" & 4", Graphite fiber reinforced vinyl ester resin. 6" and up, fiberglass-reinforced VE.
- (3) **Seat:** 3"-8": Viton GF or PTFE. 10", 12": Viton GF
- (4) **Stem:** 17-4 PH stainless steel with molded graphite fiber-reinforced vinyl ester on all wetted surfaces. Hastelloy-C insert is optional.
- (5) **Gland:** Hastelloy-C.
- (6) **Gland Bolts:** Hastelloy-C
- (7) **Packing:** Virgin PTFE adjustable V-rings.
- (8) **Disc Spacer:** Graphite fiber-reinforced Kynar (PVDF).
- (9) **Stem Pin:** Graphite reinforced Kynar (PVDF). Hastelloy-C optional.

4. DESIGN

- Face-to-face dimensions shall be as shown on Page 2.
- Stems shall be of blowout proof design.
- Packing shall be adjustable V-ring type.
- Valve design shall be such that it can be bolted into a standard PTFE-lined steel pipe and the valve disc not interfere with the lining of the pipe.
- Valve seat and disc geometry shall provide a 360° uninterrupted bubble tight seal from full vacuum to rated valve pressure.
- Gear or lever handle shall be available on all sizes.
- Valves shall be capable of on-off actuation or modulating control with pneumatic, electric or hydraulic actuators.

5. TESTING

- The Manufacturer's facility shall be certified to ISO 9001 or equivalent. The Manufacturer shall be certified to the European Pressure Equipment Directive (PED) and the "CE" mark shall be affixed to each valve label.
- Each valve shall be hydrostatically tested with water at not less than 1.5 times its operating pressure limit with the disc open and both ends blanked with no evidence of leakage.
- Each valve shall be subjected to a hydrostatic seat test at not less than 110% of the rated shutoff pressure and an air test at 20 psig with no evidence of leakage.

6. PACKING AND SHIPPING

Valves shall be shipped in the closed position. Each valve shall be marked with the manufacturer, size, series, construction materials, serial number, and valve component designation.

7. AVAILABILITY

Valves meeting this specification are available from:

Nil-Cor[®], LLC
4855 Broadmoor Ave.
Kentwood, MI 49512
P: 616-554-3100
F: 616-554-5623
www.nilcor.com

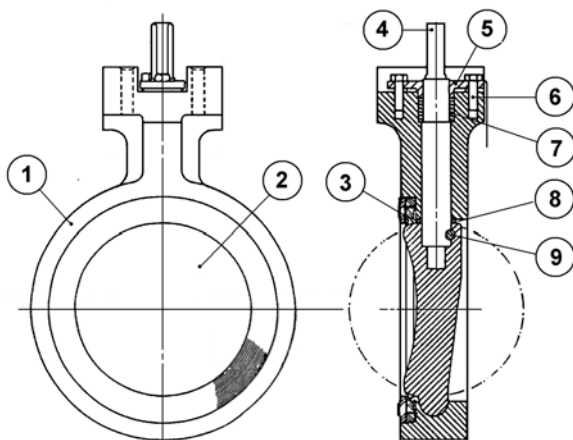

Nii-Cor WAFER BUTTERFLY VALVE DIMENSIONS

All dimensions are in Inches unless otherwise noted

2 HOLES 3/8-16 NC X 0.88 DEEP FOR 10-POS. PLATE 4"-12" ONLY
 4 HOLES 0.41" DIA THRU HOLES STRADDLE CENTERLINES ON "P" BOLT CIRCLE

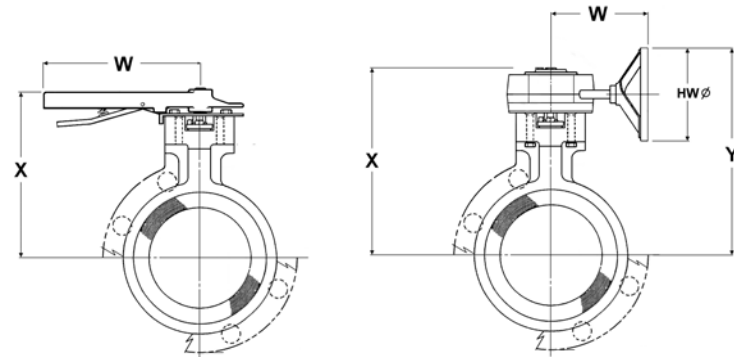
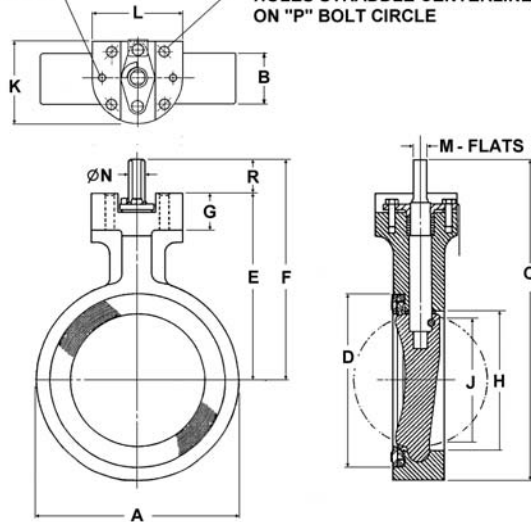

NOTE:
 Body scalloped slightly on O.D. sizes 4, 8, 10 & 12 for DIN bolt clearance

SIZE	A	B	C	D	E	F	G	H	J	K	L
3	5.38	1.81	10.25	4.13	6.38	7.56	1.50	3.13	2.38	3.13	3.50
4	6.88	2.05	12.25	5.45	7.13	8.81	1.50	4.13	3.39	3.63	4.00
6	8.75	2.20	14.00	7.45	8.13	9.68	1.63	6.13	5.43	3.63	4.00
8	11.00	2.36	16.88	9.53	9.50	11.38	1.63	8.13	7.54	3.63	4.00
10	13.38	2.67	20.00	11.51	11.38	13.31	2.13	10.06	9.50	3.94	4.00
12	16.13	3.07	23.00	13.51	12.88	14.94	2.13	12.06	11.42	3.94	4.00

Shut-off Pressure/Temperature Rating

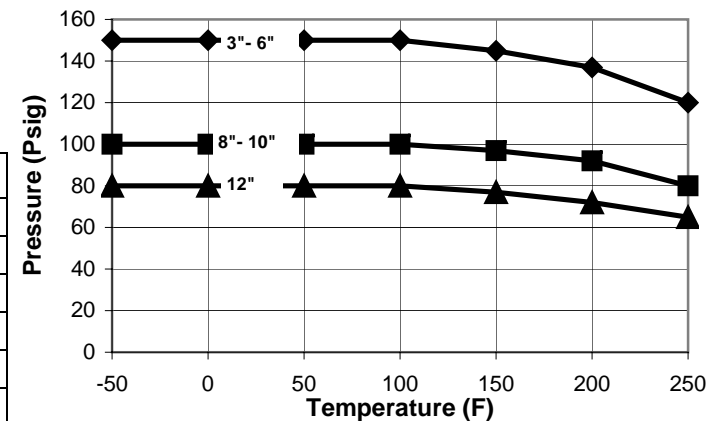

SIZE	ACTUATOR MOUNTING DIMENSIONS				LEVER DIMENSIONS		GEAR DIMENSIONS				Cv	OPERATING TORQUE (IN-LBS)		WEIGHT (LBS.)		
	M (+.000 -0.002)	N	P	R	W	X	W	X	Y	HW		<50 psid	>50 psid	BARE	W/LEVER	W/GEAR
3	0.266	0.38	2.66	1.18	9.00	7.56	6.00	8.80	10.50	6.00	220	240	240	3.0	4.0	7.5
4	0.391	0.47	3.25	1.68	12.00	8.81	6.00	9.40	11.25	6.00	395	360	480	6.0	7.5	10.5
6	0.562	0.69	3.25	1.55	14.00	9.68	6.00	10.40	12.25	6.00	950	780	960	9.0	13.0	13.5
8	0.594	0.75	3.25	1.88	14.00	11.38	7.38	11.80	15.13	9.00	2250	1680	2160	13.0	17.0	20.0
10	0.625	0.81	3.25	1.93	NA	NA	7.38	13.80	17.00	9.00	3640	2400	4200	21.0	25.0	28.0
12	0.718	0.94	3.25	2.06	NA	NA	7.38	15.90	19.50	10.00	5180	3960	6360	34.0	38.0	47.0