

TECHNICAL SPECIFICATIONS

Flanged Ball Valves Sizes 1"- 10"
Series 610XP Fiberglass Reinf. Novolac Epoxy



1. SCOPE

Ball valves for corrosive chemical service used in construction of pressurized piping systems.

2. SERVICE RATING

Temperature rating from -50 to 300° F as shown on pressure/temperature chart on the reverse side. See Catalog 1000-Supp for temperature limits for specific chemicals.

3. MATERIALS OF CONSTRUCTION

- (1) **Body:** Compression molded fiberglass reinforced novolac epoxy resin.
- (2) **Gland:** Hastelloy-C with integral locking plate.
- (3) **Stem:** Hastelloy-C metal insert with molded graphite fiber/novolac epoxy composite on all wetted surfaces*.
- (4) **Gland Bolts:** Hastelloy-C
- (5) **Stem Packing:** PTFE V-Rings.
- (6) **Thrust Washer:** Glass and carbon-filled PTFE
- (7) **Insert:** Compression molded fiberglass reinforced novolac epoxy resin.
- (8) **Seals:** PTFE-coated FKM elastomer O-ring.
- (9) **Ball:** Compression molded graphite fibers and novolac epoxy resin.
- (10) **Seats:** Self-Relieving Virgin PTFE. Glass-filled and Cavity-Filler seats available.
- (11) **Operators:** Composite lever (1"-4"). Stainless Steel handle adapter (5"-8"). All handles have locking provision. Gear is standard on 10", and recommended on 6" & 8".

*Note: 10" stem Solid Hastelloy-C. Consult Factory for options.

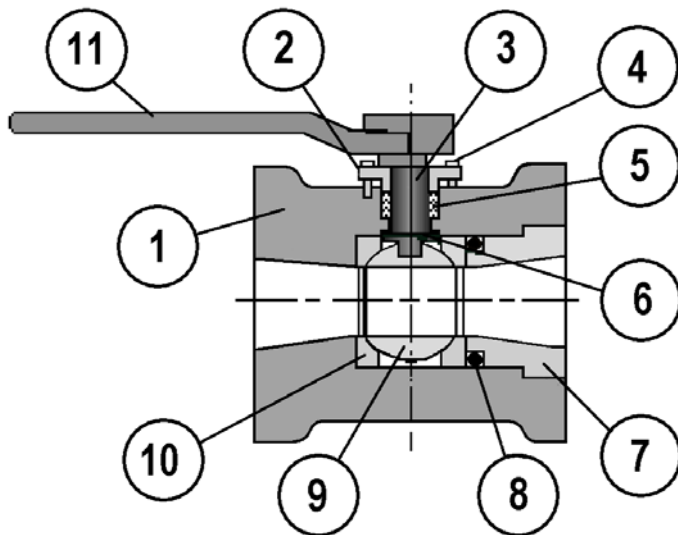

4. DESIGN

- Valves shall be flanged and conform to the face-to-face dimensions of ANSI/ASME B16.10.
- Valve shall have integral 4-bolt mounting pads and threaded holes for actuator mounting.
- Stems shall be blowout proof.
- Valves shall have a regular port with ball dimensions as shown on Page 2.
- Flanges shall be flat-faced with serrated finish to allow installation in metallic, lined metal, FRP, and thermoplastic piping systems.
- Flange bolt sizes and spacing shall conform to ANSI B16.5 Class 150. DIN, JIS and BS shall be available.
- Disassembly, maintenance and replacement of any parts shall not require machining or bonding.
- Ball and stem strength shall be sufficient to operate with abrasive particles filling the cavity.

5. QUALITY ASSURANCE

- The Manufacturer's facility shall be certified to ISO 9001 or equivalent. The Manufacturer shall be certified to the European Pressure Equipment Directive (PED) and the "CE" mark shall be affixed to each valve label.
- Each valve shall be hydrostatically shell tested at no less than 1.43x its rated cold working pressure for 3 minutes.
- Each valve shall be seat tested with air at 20 and 80 psig. The seat test pressure shall be applied successively to each end of the closed valve with the other end open to the atmosphere. No visible leakage shall be permitted for the duration of the tests.

6. PACKING AND SHIPPING

Valves shall be shipped in a closed position with both ends capped to exclude dirt and properly boxed to avoid damage. Each valve shall be marked with the manufacturer, valve size, model, serial number, and valve component designations.

7. AVAILABILITY

Valves meeting this specification are available from:

Nil-Cor[®], LLC
4855 Broadmoor Ave.
Kentwood, MI 49512
P: 616-554-3100
F: 616-554-5623
www.nilcor.com

Pressure/Temperature Rating

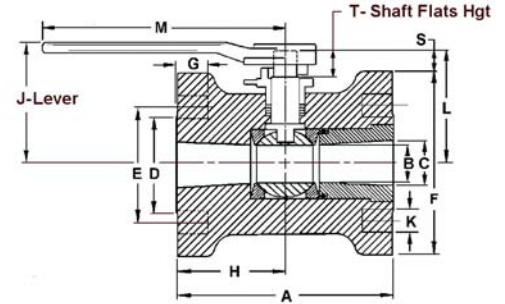
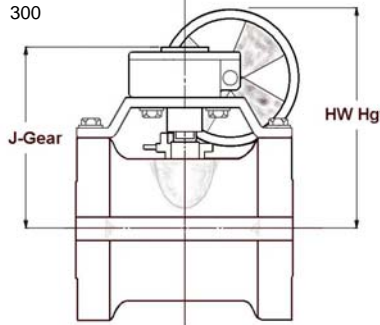
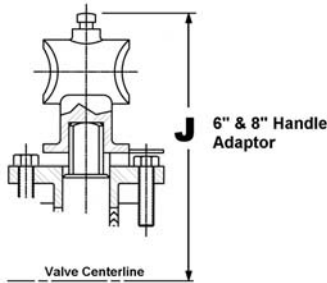
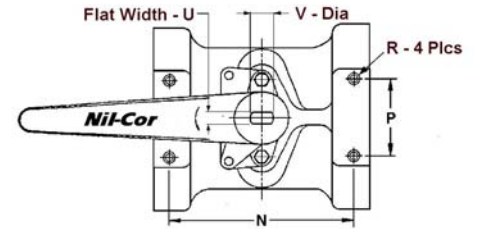
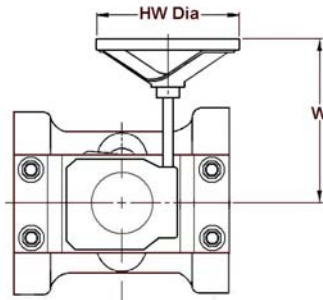
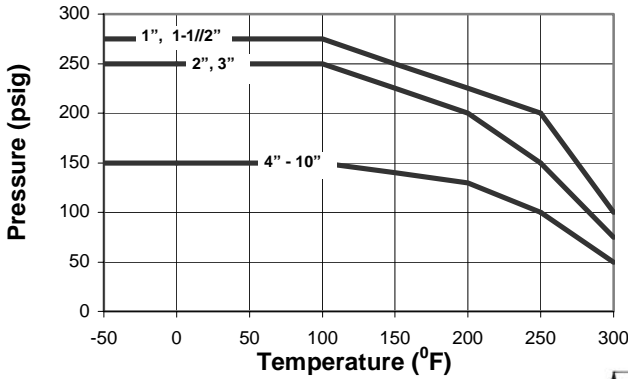

Note: Use 18" length of 1" sch. 40 pipe w/handle adaptor

SIZE	A	B	C	D	E	F	G	H	J-Lever	J-Gear	HW Dia	HW Hgt	K	K (QTY)	L	M	W
1"	5.00	.88	1.00	2.25	3.13	4.25	.88	2.50	3.08	5.60	8	8.00	.62	4	2.77	6.25	6.32
1-1/2"	6.50	1.25	1.50	3.00	3.88	5.00	1.00	3.25	3.73	6.53	8	8.92	.62	4	3.55	6.25	6.32
2"	7.00	1.50	2.00	3.66	4.75	6.00	1.00	3.50	4.18	6.71	8	9.11	.75	4	3.96	9.00	6.32
2-1/2"	7.50	1.88	2.50	4.25	5.50	7.00	1.19	3.75	5.44	8.52	8	10.92	.75	4	5.17	9.00	6.32
3"	8.00	2.31	3.00	5.00	6.00	7.50	1.36	4.00	5.58	8.52	8	10.92	.75	4	5.42	9.00	6.32
4"	9.00	3.00	4.00	6.19	7.50	9.00	1.50	4.50	7.05	9.56	8	11.96	.75	8	6.50	11.44	6.32
5"	10	3.75	5.00	7.50	8.50	10.00	1.50	5.00	7.75	11.08	12	14.46	.88	8	7.21	Note 4	7.39
6"	10.50	4.50	6.00	8.50	9.50	11.00	1.63	5.25	10.51	11.58	12	14.96	.88	8	7.91	Note 4	7.39
8"	11.50	6.00	8.00	11.25	11.75	13.50	1.75	5.75	11.77	13.00	12	17.11	.88	8	9.21	Note 4	8.77
10"	13.00	7.50	10.00	14.00	14.25	16.00	2.00	6.50	NA	13.64	18	17.50	1.00	12	11.10	NA	8.77

Valve Size	Actuation Mounting Dimensions							Actuation Torque (in-lbs.)			Weight (Lbs.)		
	N	P	R x (deep ¹)	S	T	+0.000-.010 U	+0.000-.010 V	Valve Running Torque ⁽²⁾	Breakaway Torque ⁽³⁾ 0-100 psi	Breakaway Torque ⁽³⁾ >100 psi	Flow Coeff. Max Cv	w/o Gear (lbs.)	With Gear (lbs.)
1"	4.18	1.75	5/16 - 18 x 1/2	0.64	0.50	0.375	0.500	90	140	160	75	3	9
1-1/2"	5.62	1.75	5/16 - 18 x 1/2	1.05	0.70	0.375	0.500	125	190	230	115	6	12
2"	6.18	2.25	5/16 - 18 x 5/8	0.96	0.75	0.375	0.625	150	230	270	135	8	15
2-1/2"	6.62	2.63	3/8 - 16 x 3/4	1.67	0.75	0.500	0.880	260	400	475	250	13	20
3"	7.12	3.50	3/8 - 16 x 3/4	1.67	0.75	0.500	0.875	370	570	680	350	14	21
4"	8.00	4.00	7/16 - 14 x 7/8	2.00	1.13	0.750	1.000	680	1040	1250	540	23	30
5"	9.00	4.75	7/16 - 14 x 7/8	2.21	1.13	0.750	1.000	1000	1570	1825	1000	33	46
6"	9.00	5.25	7/16 - 14 x 1-1/8	2.41	1.13	0.750	1.000	1400	2100	2400	1240	40	53
8"	9.75	6.00	1/2 - 13 x 1-7/16	2.46	1.13	1.094	1.250	2800	4200	4800	2200	65	90
10"	11.25	7.75	1/2 - 13 x 1-1/4	3.10	1.13	1.258	1.438	4100	6300	7200	2600	100	125

- Minimum thread engagement required to develop design joint strength on the actuator mounting pad (composite valve body).
- Flowing fluid, ball in motion between 0 and 90 deg.
- Maximum breakaway torque for clean liquid service.
- For manual 5"-8" size, use handle adaptor or gear operator. Gear only on 10"