

TECHNICAL SPECIFICATIONS

Wafer Swing Check Valves Sizes 2"- 16"

Series 310 Fiberglass Reinforced Vinyl Ester



1. SCOPE

Swing Check Valves for corrosive chemical service used in construction of pressurized piping systems.

2. SERVICE RATING

Temperature rating from 0° F to 250° F as shown on pressure/temperature chart on the reverse side. See Catalog 1000 for temperature limits for specific chemicals.

3. MATERIALS OF CONSTRUCTION

- (1) Body: Glass fiber-reinforced vinyl ester resin, complete with integrally molded disc support slot.
- (2) Disc: Glass fiber-reinforced vinyl ester
- (3) Seat: PTFE or Viton Option
- (4) Lifting Eye: Stainless Steel

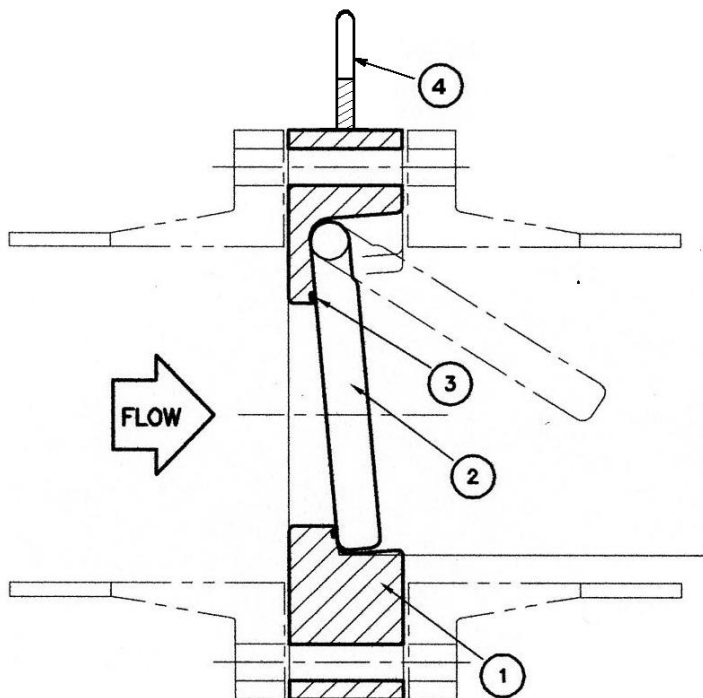

4. DESIGN

- Valves shall be full face wafer design and conform to the face-to-face dimensions specified on Page 2.
- A flow arrow on the body indicating the direction of free flow shall be provided.
- Flanges shall be flat-faced with serrated finish.
- Flange bolt sizes and spacing shall conform to ANSI B16.5 Class 150.
- Vertical and horizontal pressure drop to unseat shall be less than 1 psi.
- Disc will self-seat without a requirement for backflow in vertical or horizontal lines.
- A lifting lug shall be provided for installation ease on all sizes.

5. QUALITY ASSURANCE

- The Manufacturer's facility shall be certified to ISO 9001 or equivalent. The Manufacturer shall be certified to the European Pressure Equipment Directive (PED) and the "CE" mark shall be affixed to each valve label.
- Each valve shall be hydrostatically shell tested at 1.5x its rated cold working pressure for 3 min.
- Each valve shall be seat tested with water at 20 psig and 1.10 x rated shutoff. No visible leakage shall be permitted for the duration of the tests.

6. PACKING AND SHIPPING

- Valves shall be shipped with both ends capped to exclude dirt and retain the disc, and properly boxed.
- Each valve shall be marked with the manufacturer, valve size, model, serial number, and valve component designations.

7. AVAILABILITY

Valves meeting this specification are available from:

Nil-Cor®, LLC
4855 Broadmoor Ave.
Kentwood, MI 49512
P: 616-554-3100
F: 616-554-5623
www.nilcor.com

Wafer Swing Check Valve Dimensions And Technical Specifications

**Shutoff Pressure/Temperature Rating
Wafer Swing Check**

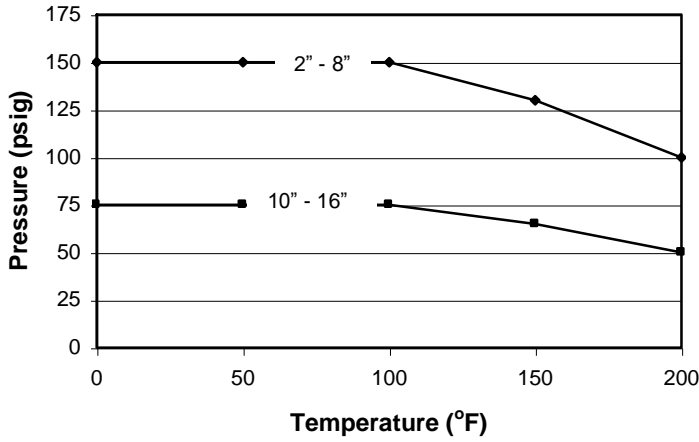

Installation Dimensions (Inches)

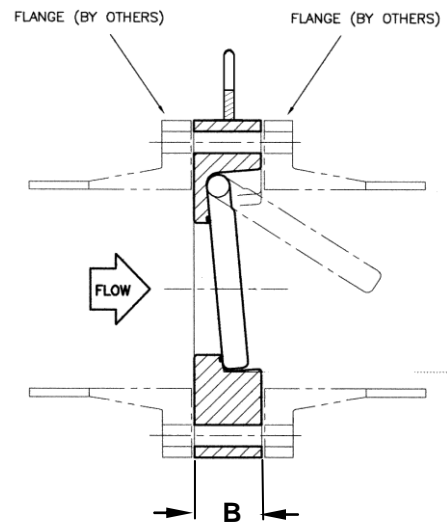
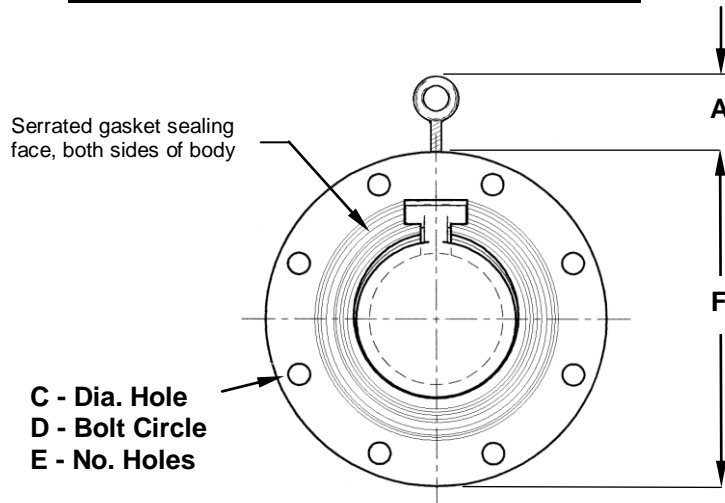

SIZE	A	B	C	D	E	F	WT (Lbs)	Cv
2"	1.97	1.69	0.75	4.75	4	6.00	7.50	35
3"	1.50	1.81	0.75	6.00	4	7.50	8.50	95
4"	1.50	1.81	0.75	7.50	8	9.00	11.50	230
6"	1.50	2.25	0.88	9.50	8	11.00	15.50	650
8"	2.00	2.63	0.88	11.75	8	13.50	21.00	1,350
10"	2.00	2.67	1.00	14.25	12	16.00	27.80	1,960
12"	2.50	3.07	1.00	17.00	12	19.00	37.50	3,200
14"	2.50	3.75	1.125	18.75	12	21.00	52.00	3,720
16"	2.50	4.12	1.125	21.25	16	23.50	75.00	4,800